

# TAPPING SERVICE SADDLE

to steel / iron / AC and PCV/PE



## Type : Tapping branch saddle to iron/steel/AC/PCV/PE – PN 10/16



### Materials and construction characteristic :

**Tapping saddle** – made of nodular iron EN GJS-500-7. Saddle could be connected to the valve body by thread outlet

Tapping saddle include steel strap made of stainless steel grade 1.4301 with screw ends. Screw could be simple or T-shape accordance to customer request. Steel band is covered with the rubber at the whole surface and include spherical pads what guarantee optimal pipe tapping angle

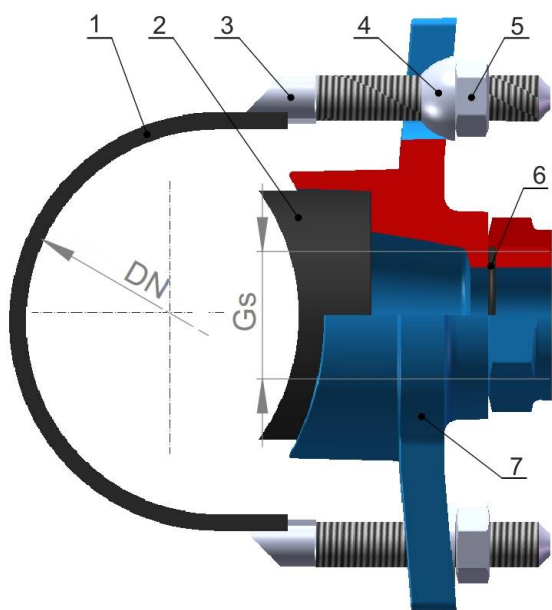

1. Steel strap
2. Saddle gasket
3. Screw
4. Spherical pad
5. Nut
6. Gasket
7. Tapping saddle

### Technical specification :

DN [mm]	Gs [“ / mm]	Catalogue no.	Weight [kg]
80-350	6” / 40	8020	4 – 6
	2” / 50	8030	
		8040	

Reflecting continuous progress of product development we reserve right for further construction changes or to produce product accordance to customer request.

### Application :

- Tapping saddle available in diameter range DN80-350 (other diameters at special customer request)
- In installations: water, portable water and other inert fluids at max. 60 ° C
- Suitable to direct underground installation
- Fully secured against corrosion with powder paint designed to direct contact with drinking water
- Minimum paint level 250 µm color RAL 5015
- Production repeatability and quality guarantee accordance to EN ISO 9001:2008
- Hygienic certificate by National Health Institute – “PZH”

Tel. +48 (61) 427-22-45  
Fax. +48 (61) 429-21-90  
Mob. +48 694-434-602 / 883-321-851  
marketing@efekt.gniezno.pl  
inquiry@efekt.gniezno.pl  
Skype : phuefekt\_gniezno



Unia Europejska



PROGRAM  
REGIONALNY

NARODOWA STRATEGIA SPÓJNOŚCI

EFRR – WRPO 2007- 2013